



## SERIES: FL

**INTERCHANGE:** ISO 16028 and NFPA T3.20.15 (HTMA)

### MAIN APPLICATIONS

- Offshore - Marine
- Chemical - Pharmaceutical
- Industrial equipment
- Food Industry

The "FL" flat face coupling series is the Stucchi solution for applications in high corrosion environments and/or for corrosive fluid transfer.

The "FL" couplings are manufactured in stainless steel AISI 316, standard seals are Viton / Fluorocarbon with the option of other seal materials upon request for use with various fluids and operating temperatures. The features of flat face couplings in stainless steel to eliminate leakage during connection-disconnection, reduce contamination in the circuit, and offer optimal resistance to corrosion make "FL" series ideal for applications such as: offshore, marine, industrial equipment, chemical, Pharmaceutical and food processing.



**Stucchi**<sup>®</sup>

A CONSTANT FLOW OF SOLUTIONS

## TECHNICAL FEATURES AND OPTIONS

- Interchangeability: ISO 16028 (from size 6.3 to 25) HTMA (size 10)
- Valve system: Flat face
- Mechanical connection: Locking balls
- Connection system: Pushing to connect
- Disconnection system: Pushing back the sleeve of female
- Connection with residual pressure: Not allowed
- Disconnection with residual pressure: Not allowed
- Threads available: BSP, NPT
- Threads on request: SAE (J1926-1)
- Construction material: Stainless steel AISI 316
- Springs: AISI 302
- Locking ball material: AISI 316
- Seals: Standard in VITON
- Seals on request: NBR (Nitrile), EPDM, KALREZ or others
- Anti-extrusion rings: PTFE
- Accessories on request: Caps in AISI 316

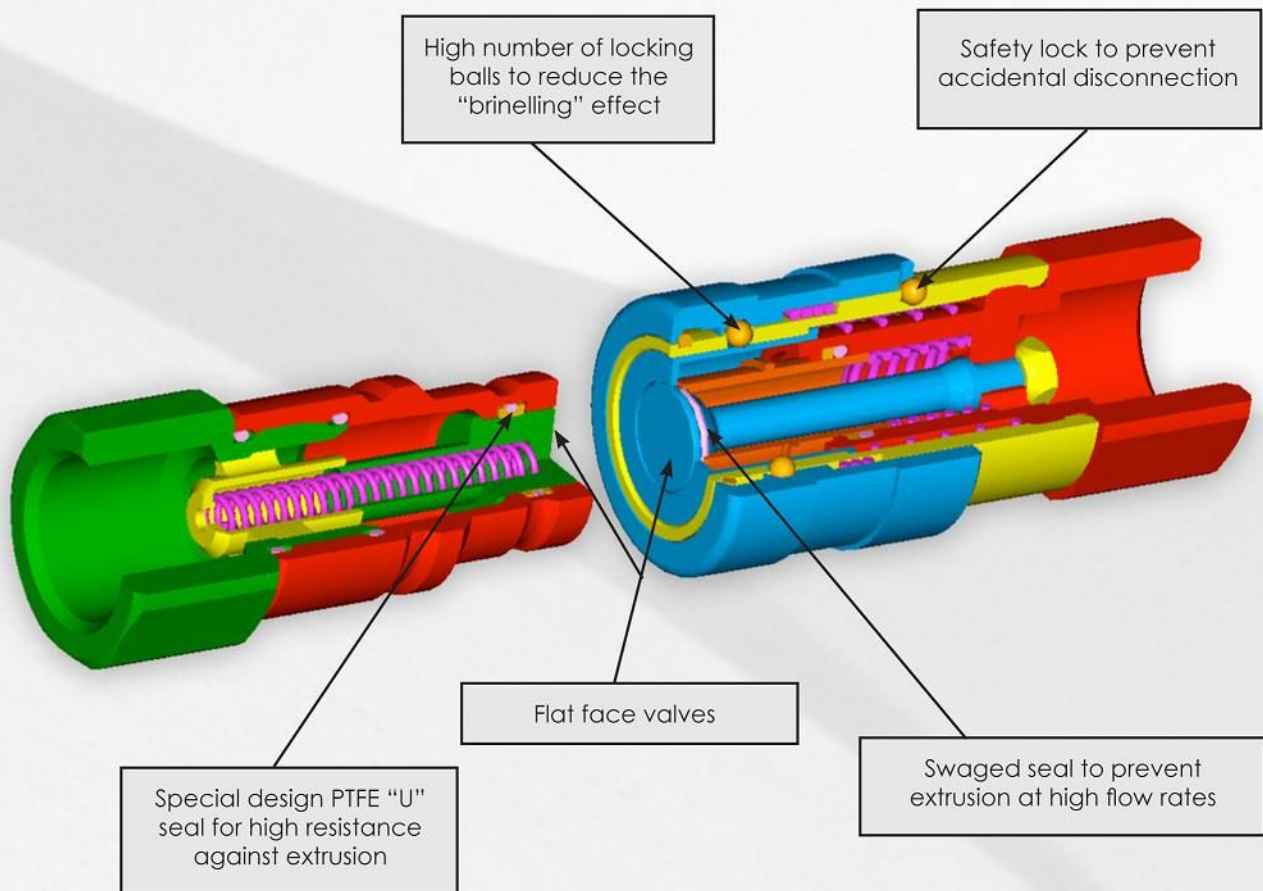

## BENEFITS

- Flat face is easy to clean, helping to reduce the inclusion of contamination to the hydraulic circuit.
- Minimal fluid loss during connection / disconnection, reducing fluid loss to the environment.
- Minimal air inclusion during connection / disconnection, enhancing correct function of the circuit.
- Linear flow reduces internal turbulence and pressure drop, maintaining circuit efficiency in the entire system.
- Optimal resistance to the corrosion for long life of couplings.
- Compact slim design.
- Safe and simple to use.

## HOW TO USE

- Before to couple clean the flat mating surface of quick coupling to avoid the inclusion of dirty in the circuit.
- To couple push the male half towards the female half or vice versa.
- After connection turn the external sleeve to engage lock function, to prevent accidental disconnection.
- To uncouple turn the external sleeve until the sleeve lock groove corresponds with the safety lock ball and pull back the sleeve.

## WARNING!

- Do not use the female coupling disconnected with impulse pressure.
- Do not couple-uncouple with flow and/or pressure in the circuit.
- Do not couple-uncouple when the temperature inside of the circuit is higher than 80 °C (176 °F).
- When the couplings are disconnected, it is suggested to use the protection caps.  
The plastic caps of "FIRG-A" series are suitable for "FL" couplings.  
On request caps in stainless steel AISI 316.

## PERFORMANCE

Description	Size	ISO Size	Rated flow		Max. flow suggested		Connect force		Disconnect force		Spillage *
			l/min	GPM	l/min	GPM	N	lbf	N	lbf	
	Inch	mm									ml
FL4	1/8	-	3	0,80	6	1,59	140	31,50	30	6,75	0,005
FL7	1/4	6,3	12	3,18	24	6,36	160	36,00	45	10,13	0,006
FL9	3/8	10,0	23	6,10	46	12,19	160	36,00	45	10,13	0,012
FL13	1/2	12,5	45	11,93	90	23,85	200	45,00	60	13,50	0,020
FL15	5/8	16,0	74	19,61	148	39,22	200	45,00	60	13,50	0,026
FL17	3/4	19,0	100	26,50	200	53,00	200	45,00	60	13,50	0,032
FL21	1	25,0	189	50,09	378	100,17	280	63,00	90	20,25	0,035
FL27	1-1/2	-	288	76,32	750	198,75	580	130,50	160	36,00	0,050
FL45	2	-	379	100,44	1000	265,00	490	110,25	70	15,75	0,100

Description	Max. operating pressure						Burst pressure					
	Coupled		Male		Female		Coupled		Male		Female	
	MPa	psi	MPa	psi	MPa	psi	MPa	psi	MPa	psi	MPa	psi
FL4	35	5075	35	5075	33	4785	140	20300	140	20300	120	17400
FL7	35	5075	35	5075	12	1740	140	20300	120	17400	48	6960
FL9	35	5075	35	5075	15	2175	140	20300	120	17400	60	8700
FL13	35	5075	35	5075	15	2175	120	17400	110	15950	60	8700
FL15	35	5075	30	4350	12	1740	120	17400	100	14500	48	6960
FL17	33	4785	28	4060	12	1740	100	14500	80	11600	48	6960
FL21	28	4060	28	4060	12	1740	90	13050	80	11600	48	6960
FL27	23	3335	23	3335	8	1160	80	11600	70	10150	32	4640
FL45	15	2175	15	2175	7	1015	60	8700	60	8700	28	4060

\* Spillage is an indicative value of the fluid loss per couple-uncouple cycle.

- Temperature range:
  - Standard seals VITON : from -15°C to +180°C ( from +5 °F to +356 °F).
  - NBR (Nitrile) seals: from -20 °C to +100 °C ( from -4 °F to +212 °F).
  - EPDM (Ethylene Propylene) seals: from -40 °C to +150 °C ( from -40 °F to +302 °F).
  - KALREZ seals: from -25 °C to +300 °C ( from -13 °F to +572 °F).

The couplings with Kalrez seals for high temperature use, can be used at max. operating pressure of 5 Mpa (150 psi).

- Tests:
  - The couplings have been tested at max. operating pressure for 100.000 impulses in according with ISO 7241-2.

PRESSURE DROP

TESTS ESEGUITI IN CONFORMITA' A ISO 7241-2  
 TESTS IN ACCORDANCE WITH ISO 7241-2

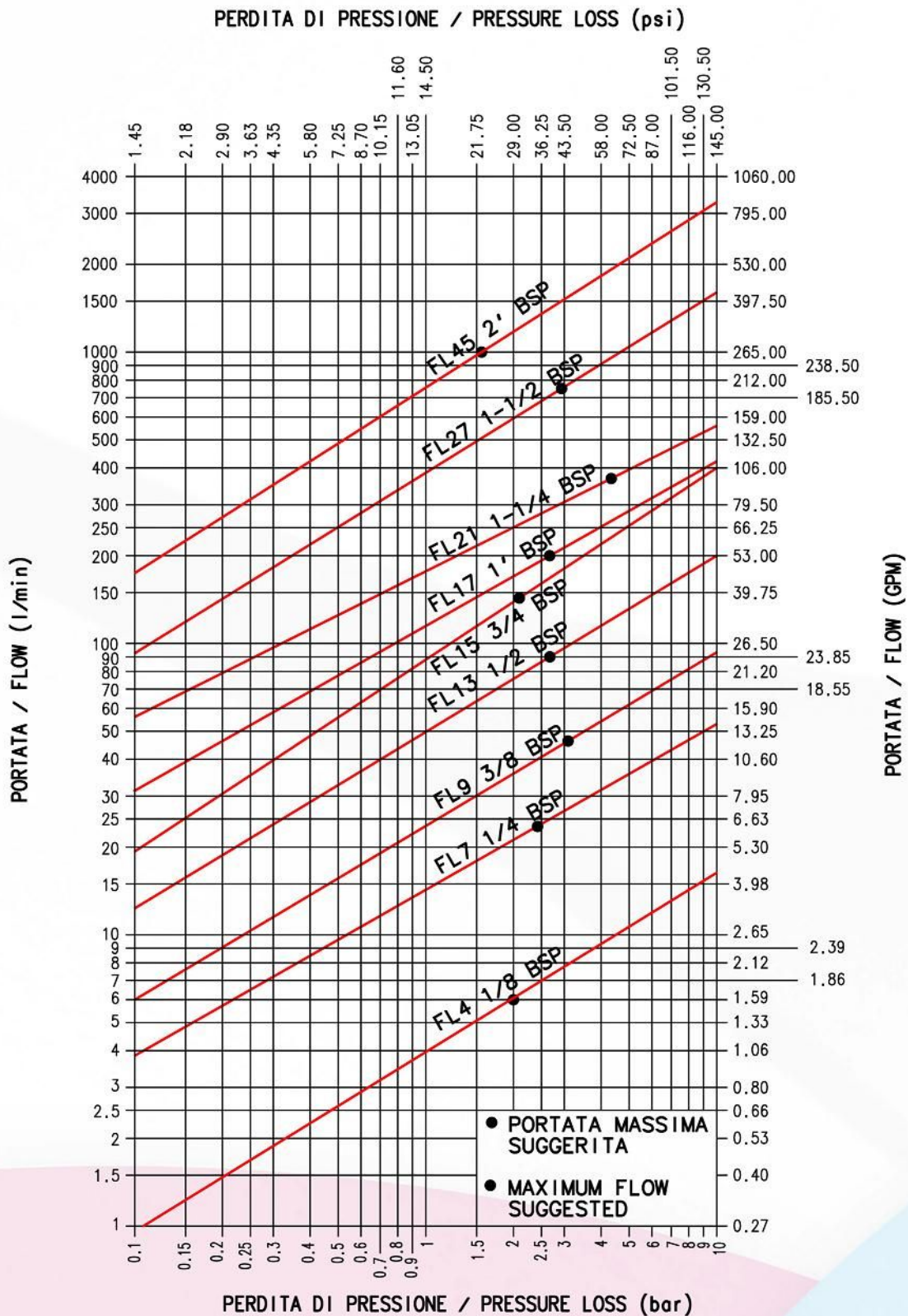

FLUIDO: OLIO ISO VG32  
 TEMPERATURA: 40°C  
 VISCOSITA': 28.8-35.2 mm<sup>2</sup>/s

FLUID: OIL ISO VG32  
 TEMPERATURE: 40°C  
 VISCOSITY: 28.8-35.2 mm<sup>2</sup>/s

## OVERALL DIMENSIONS

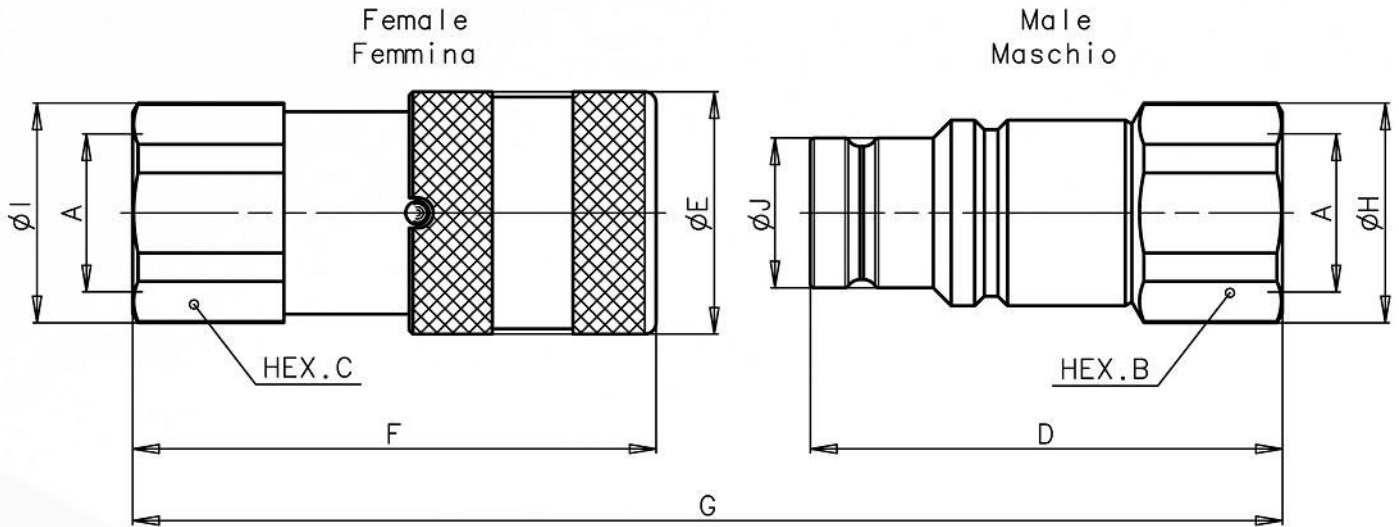

## FEMALE BSP THREAD (DIN 3852)

Description	A	Unit	B	C	D	E	F	G	H	I	J	Unit	Weight	
													Male	Female
FL4 1/8 BSP	1/8	mm Inch	17 0,67	19 0,75	36,3 1,43	20 0,79	40 1,57	68,4 2,69	18,5 0,73	20,5 0,81	11,6 0,46	Kg lb	0,037 0,08	0,074 0,16
FL7 1/4 BSP	1/4	mm Inch	22 0,87	22 0,87	49,4 1,94	28 1,10	48,3 1,90	86,7 3,41	23,8 0,94	23,8 0,94	16,1 0,63	Kg lb	0,098 0,22	0,142 0,31
FL9 3/8 BSP	3/8	mm Inch	24 0,94	27 1,06	59,9 2,36	32 1,26	64,2 2,53	108,6 4,28	26 1,02	29 1,14	19,7 0,78	Kg lb	0,124 0,27	0,245 0,54
FL9 1/2 BSP	1/2	mm Inch	27 1,06	27 1,06	62,4 2,46	32 1,26	69,2 2,72	116,1 4,57	29 1,14	29 1,14	19,7 0,78	Kg lb	0,120 0,26	0,242 0,53
FL13 1/2 BSP	1/2	mm Inch	32 1,26	32 1,26	70,5 2,78	38 1,50	73,8 2,91	127 5,00	33,8 1,33	33,8 1,33	24,5 0,96	Kg lb	0,259 0,57	0,378 0,83
FL13 3/4 BSP	3/4	mm Inch	36 1,42	36 1,42	70,5 2,78	38 1,50	80,8 3,18	134 5,28	38,5 1,52	38,5 1,52	24,5 0,96	Kg lb	0,255 0,56	0,375 0,83
FL15 3/4 BSP	3/4	mm Inch	36 1,42	36 1,42	70,5 2,78	42 1,65	80,9 3,19	133,8 5,27	38,5 1,52	38,5 1,52	27 1,06	Kg lb	0,282 0,62	0,492 1,08
FL17 1 BSP	1	mm Inch	46 1,81	46 1,81	82,2 3,24	48 1,89	92,9 3,66	153,3 6,04	49,5 1,95	49,5 1,95	30 1,18	Kg lb	0,432 0,95	0,795 1,75
FL21 1-1/4 BSP	1-1/4	mm Inch	55 2,17	55 2,17	90 3,54	55 2,17	106,2 4,18	173 6,81	59,8 2,35	59,8 2,35	36 1,42	Kg lb	0,672 1,48	1,226 2,70
FL27 1-1/2 BSP	1-1/2	mm Inch	70 2,76	65 2,56	111 4,37	80 3,15	132,4 5,21	214,8 8,46	76 2,99	72 2,83	57 2,24	Kg lb	1,890 4,17	2,908 6,41
FL45 2 BSP	2	mm Inch	75 2,95	80 3,15	123,8 4,87	100 3,94	156,6 6,17	241,5 9,51	83,5 3,29	88,5 3,48	73 2,87	Kg lb	2,290 5,05	5,230 11,53

## OVERALL DIMENSIONS

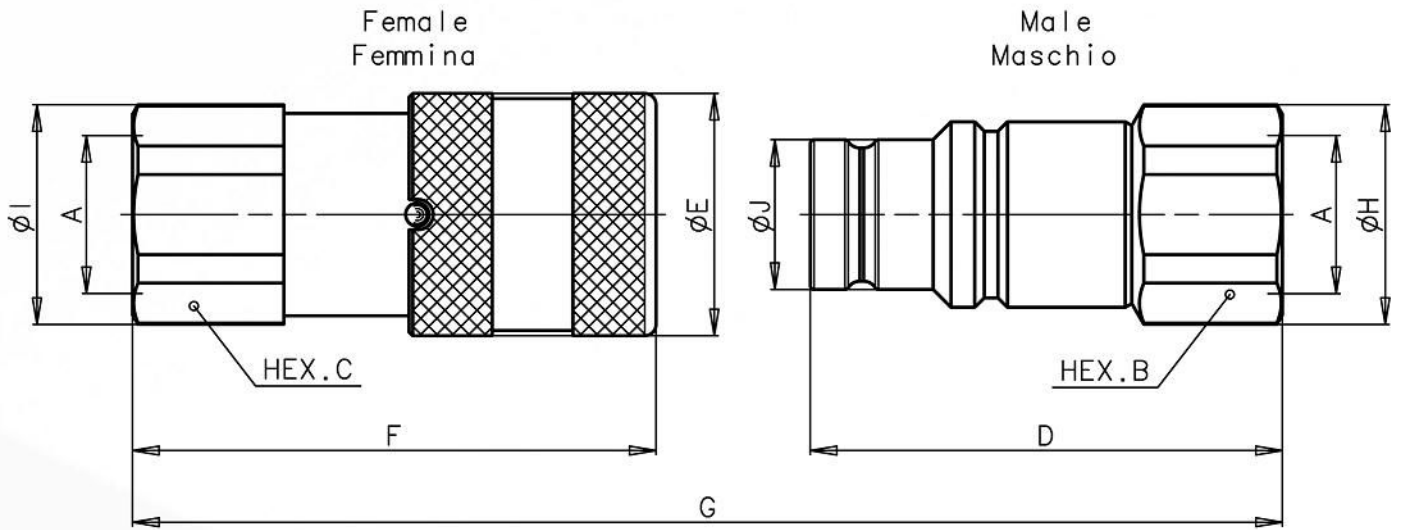

## FEMALE NPT THREAD (ANSI B.1.20.3)

Description	A	Unit	B	C	D	E	F	G	H	I	J	Unit	Weight	
													Male	Female
FL4 1/8 NPT	1/8	mm Inch	17 0,67	19 0,75	36,3 1,43	20 0,79	40 1,57	68,4 2,69	18,5 0,73	20,5 0,81	11,6 0,46	Kg lb	0,040 0,09	0,075 0,17
FL7 1/4 NPT	1/4	mm Inch	22 0,87	22 0,87	47,9 1,89	28 1,10	48,3 1,90	85,2 3,35	23,8 0,94	23,8 0,94	16,1 0,63	Kg lb	0,094 0,21	0,143 0,32
FL9 3/8 NPT	3/8	mm Inch	24 0,94	27 1,06	59,9 2,36	32 1,26	64,2 2,53	108,6 4,28	26 1,02	29 1,14	19,7 0,78	Kg lb	0,137 0,30	0,245 0,54
FL9 1/2 NPT	1/2	mm Inch	27 1,06	27 1,06	62,4 2,46	32 1,26	69,2 2,72	116,1 4,57	29 1,14	29 1,14	19,7 0,78	Kg lb	0,135 0,30	0,242 0,53
FL13 1/2 NPT	1/2	mm Inch	32 1,26	32 1,26	68 2,68	38 1,50	73,8 2,91	124,5 4,90	33,8 1,33	33,8 1,33	24,5 0,96	Kg lb	0,259 0,57	0,378 0,83
FL13 3/4 NPT	3/4	mm Inch	36 1,42	36 1,42	70,5 2,78	38 1,50	80,8 3,18	134 5,28	38,5 1,52	38,5 1,52	24,5 0,96	Kg lb	0,266 0,59	0,416 0,92
FL15 3/4 NPT	3/4	mm Inch	36 1,42	36 1,42	70,5 2,78	42 1,65	80,9 3,19	133,8 5,27	38,5 1,52	38,5 1,52	27 1,06	Kg lb	0,280 0,62	0,495 1,09
FL17 1 NPT	1	mm Inch	46 1,81	46 1,81	82,2 3,24	48 1,89	92,9 3,66	153,3 6,04	49,5 1,95	49,5 1,95	30 1,18	Kg lb	0,432 0,95	0,810 1,79
FL21 1-1/4 NPT	1-1/4	mm Inch	55 2,17	55 2,17	90 3,54	55 2,17	106,2 4,18	173 6,81	59,8 2,35	59,8 2,35	36 1,42	Kg lb	0,672 1,48	1,226 2,70
FL27 1-1/2 NPT	1-1/2	mm Inch	70 2,76	65 2,56	111 4,37	80 3,15	132,4 5,21	214,8 8,46	76 2,99	72 2,83	57 2,24	Kg lb	1,896 4,18	2,908 6,41
FL45 2 NPT	2	mm Inch	75 2,95	80 3,15	123,8 4,87	100 3,94	156,6 6,17	241,5 9,51	83,5 3,29	88,5 3,48	73 2,87	Kg lb	2,290 5,05	5,230 11,53

The texts, data and illustrations indicated in this catalogue, may be changed by Stucchi S.p.A at any time without notice. (CAT. FL- March 2008).